



SUBMITTAL

WB-SERIES

WESPAC BRAZED PLATE HEAT EXCHANGER

Models: WB01 thru WB30

Submittal Sheet No. M-1003A

Date: 9/20

Job Name _____	Submitted By _____	Date _____
Location _____	Approved By _____	Date _____
_____	Order No. _____	Date _____
Engineer _____	Notes _____	
Contractor _____	_____	
Sales Rep. _____	_____	

Description

Wessels type WB-series WesPac brazed plate heat exchangers are ASME certified and designed to efficiently transfer heat from one fluid to another. The fluids are separated by corrosion resistant heat transfer plates that are bound together using brazing material.

Construction

Plate Material: 316SS
 Connection Material: 316SS
 Braze Material: Copper

Performance Limitations

Maximum Design Temperature: 325
 Maximum Design Pressure: 435 PSIG

*For alternative materials and pressures consult factory

Model Number	Max # of plates	Max Flow (GPM)	Quantity
WB01	60	30	
WB10	100	65	
WB11	100	65	
WB15D	100	65	
WB20	160	120	
WB30	160	235	

SELECTION:

Model	Duty	W	H	L	Wt.	Tagging

Typical Specification

Furnish and install, as shown on plans, a WB_____ brazed plate heat exchanger. Each heat exchanger must be designed to have the capacity and pressure/temperature rating as detailed in the schedule. The heat exchanger shall utilize 316 stainless steel and copper brazed to separate the two. Each plate shall be Wessels model number _____ or approved equal.

25110 THOMAS DR • WARREN, MI 48091 • (586) 427-7700 • (586) 427-7895 FAX • www.aatanks.com



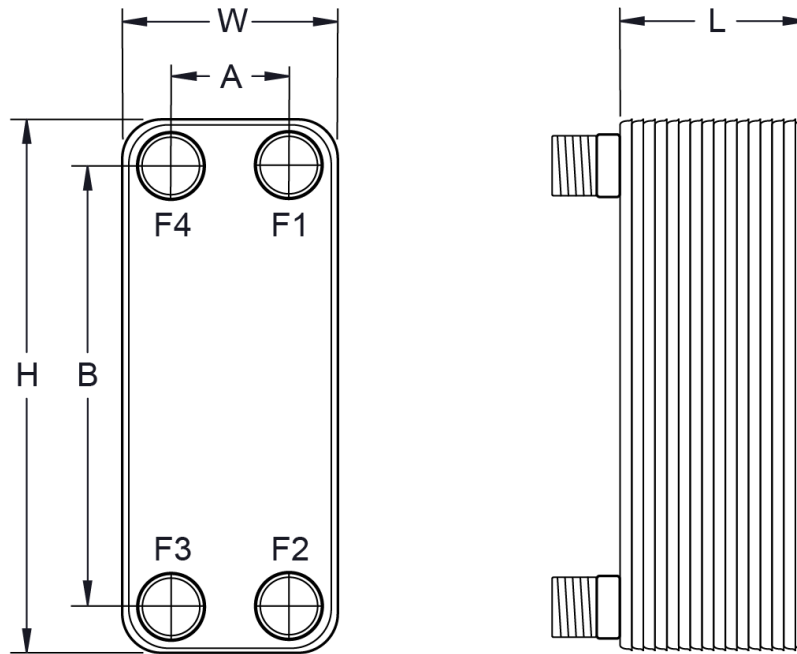

WB01 thru WB30

Dimensions & Weights

Model Number	Conn Size (in)	Max Flow (GPM)	Dimensions in Inches					Max # of Plates	Plate Area Sq. Ft.	Approx. Ship Weight (lbs)
			A	W	B	H	L			
WB01	3/4	30	7.6	3.2	6.1	1.6	0.4 + 0.1N	60	0.13	2 + 0.1N
WB10	1	65	12.0	4.2	9.8	2.0	0.5 + 0.1N	100	0.29	4 + 0.1N
WB11	1	65	20.5	4.2	18.4	2.0	0.5 + 0.1N	100	0.54	7 + 0.5N
WB15D	1	65	12.0	5.0	9.8	2.8	0.4 + 0.1N	100	0.35	4 + 0.3N
WB20	2	120	20.8	9.7	18.0	6.9	0.5 + 0.1N	160	1.22	16 + 1.1N
WB30	3	235	20.8	9.7	16.9	5.8	0.45 + 0.1N	160	1.12	19 + 1.1N

Notes

- Heat exchanger supports provided separately.
- All dimensions + / - 0.125".
- WB15D is double wall construction.